

5D KEYLINE SERIES.



5080D Keyline – 5090D Keyline – 5100D Keyline



5D Keyline series		5080	5090	5100
ENGINE				
Emissions compliance			III B	
Type			FARMotion	
Cylinders / Displacement	n°/cm ³		3/2,887	
Turbocharger with intercooling			●	
Maximum power (ECE R120) at 2,000 rpm	kW / HP	58/79	65/88	71/97
Power at rated engine speed (ECE R120) at 2200 rpm	kW / HP	55.4/75	61.6/84	67.3/92
Max. torque	Nm	342	354	369
Torque rise	%	43	32	27
Electronic engine control			●	
Fuel tank capacity	Litres		90	
TRANSMISSION				
Synchronized mechanical reverse shuttle			●	
5-speed transmission 15+15 with creeper (40 km/h ECO)			●	
5-speed transmission 30+15 with reduction and creeper (40 km/h ECO)			○	
Electro-hydr. switching of four-wheel drive and differential lock			●	
Hydraulic trailer brake (country-specific)			○	
PTO				
Mechanically controlled			●	
540/540ECO			●	
540/540ECO/1000			○	
Ground-speed PTO			○	
LIFT				
Mechanical linkage control			●	
Max. lifting capacity (STD / OPT)	kg		2,500/3,500	
Hydraulic pump	l/min		50	
Hydr. spool valves	No.		2/3	
CAB				
Digital display in the instrument cluster			●	
Adjustable steering column (height and inclination)			●	
Air conditioning			○	
High-visibility cab roof			○	
DIMENSIONS AND WEIGHTS				
Wheelbase (A)	mm		2,100	
Length (B)	mm		3,860	
Height (C) (rear axle centre - cab roof)	mm		1,820	
Total height (D)		2,470		2,495
Width (E)	mm		1,756/1,882	
Unladen weight	kg		3,200	
Permissible total weight	kg		5,200	

● = Standard ○ = Optional – = not available

Technical specifications and images are indicative only. Whilst making every effort to meet your requirements, DEUTZ-FAHR may make changes at any time and is not required to give notice thereof.

* Data for standard tyres

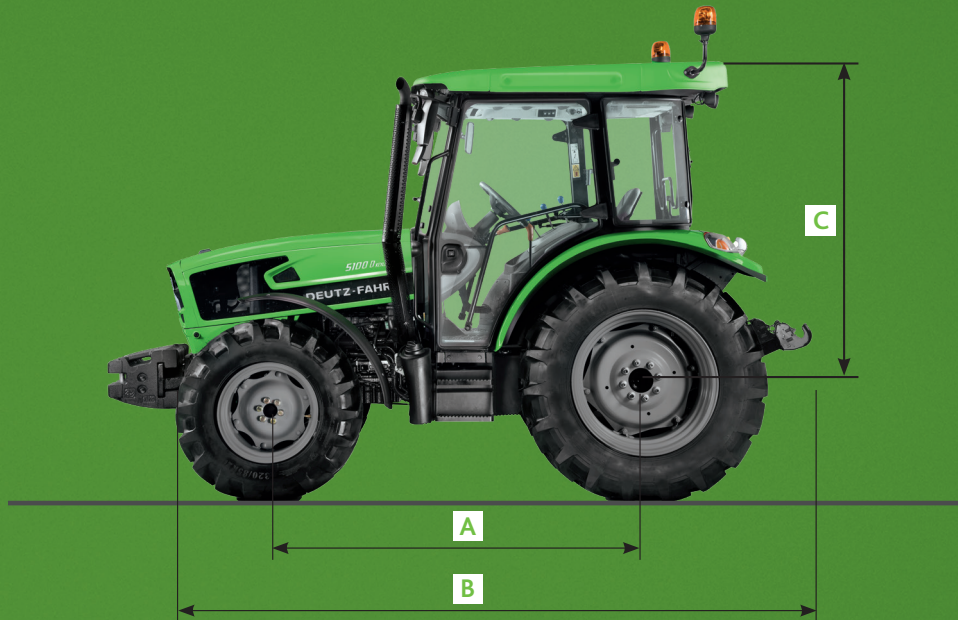
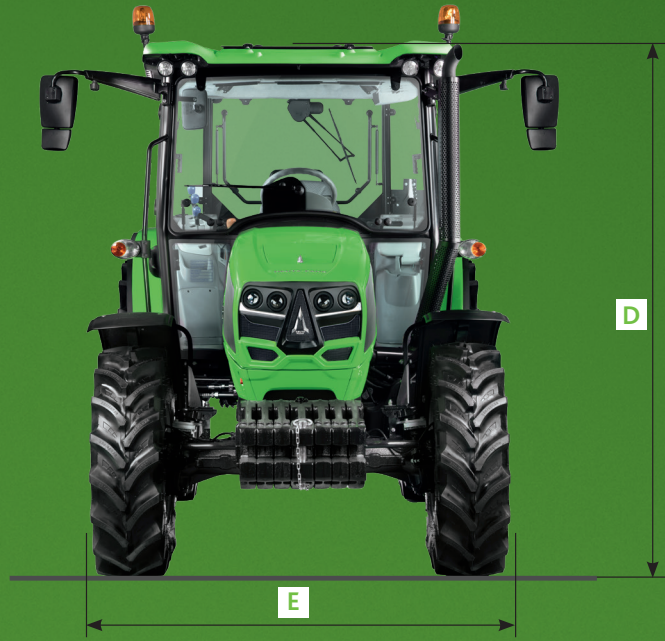

Your DEUTZ-FAHR distribution partner



Marketing-Communication Service – Code 308.8580.3.4-2 – 09/20

For more information, contact your DEUTZ-FAHR distribution partner or visit deutz-fahr.com.

DEUTZ-FAHR is a brand of  SDF

